



## Automatic Guided Vehicle Systems

Mobile Robotics Since 1982



[Transbotics.com](http://Transbotics.com) | +1 704 362 1115

# SOLUTIONS SUITE

Transbotics manufactures, installs, and supports various automation technologies, including custom, and standard AGVs, AGCs, heavy load AGVs, conveyors, batteries, chargers, motors and other related products. Transbotics provides unique automation solutions to a variety of industries, including automotive (and tier one suppliers), primary metals, food and beverage, aerospace and defense, plastics and paper and allied products.



## CONSULTATION/ DESIGN

Consultation begins by working closely with our clients to understand the application and overall system requirements. Countless variables are considered and studies are conducted down to through-put calculations. Based on this thorough assessment, our team can make recommendations and submit a proposal. Typically, 2D CAD drawings are provided first, followed by a 3D layout and simulation.



## MANUFACTURING

Once a system is established, our clients get a dedicated project management team that follows the project from start to installation. In the manufacturing stage, the team stays in close contact with the client, providing updates, photos and site visits. The team's primary goal is to deliver the system on time, on budget, and with the utmost quality control.



## INSTALLATION

Upon completion of the build process, in-house testing of the equipment is conducted, followed by FAT and shipment to site. A team is sent to the client's site to conduct installation and further testing of the system and application. Once approved, the system is ready to run.



## TRAINING

Along side the installation stage, the first training with operator(s) occurs. Operators take part in the installation process, enabling them to fully understand how to operate, trouble-shoot, and even service the vehicle. Further training can be provided upon request.



## AFTERMARKET

Our Aftermarket team offers a wide array of services to help client's run their system smoothly for the life of the vehicles. From parts, to service, to remote trouble shooting and training. Aftermarket can be reached 24 hrs a day, 7 days week to provide excellent customer service.

## Revolutionary AGV Benefits

AGVs are great for increasing efficiency and reducing costs, by helping to automate a manufacturing site or warehouse. Below are just some of the many benefits.

- Increase Labor Skill
- Less Product Damage
- Multi-shift & 24/7 Operations
- Increased Safety
- Reduced Maintenance
- Improved Accuracy





# TUGGER AGVS

Designed to tow a variety of loads including carts, trolleys, and trailers, our Tuggers can handle both light and heavy-duty applications. The vehicle can be optionally equipped with automatic hitch capability allowing the vehicle to automatically couple or decouple from a load. Our Tuggers can reach a max towing capacity of up to 29,000 Kg. and are suitable for almost every industry. This AGV offers high capacity, automatic transportation for both indoor and outdoor environments and comes in a variety of models.

## FEATURES

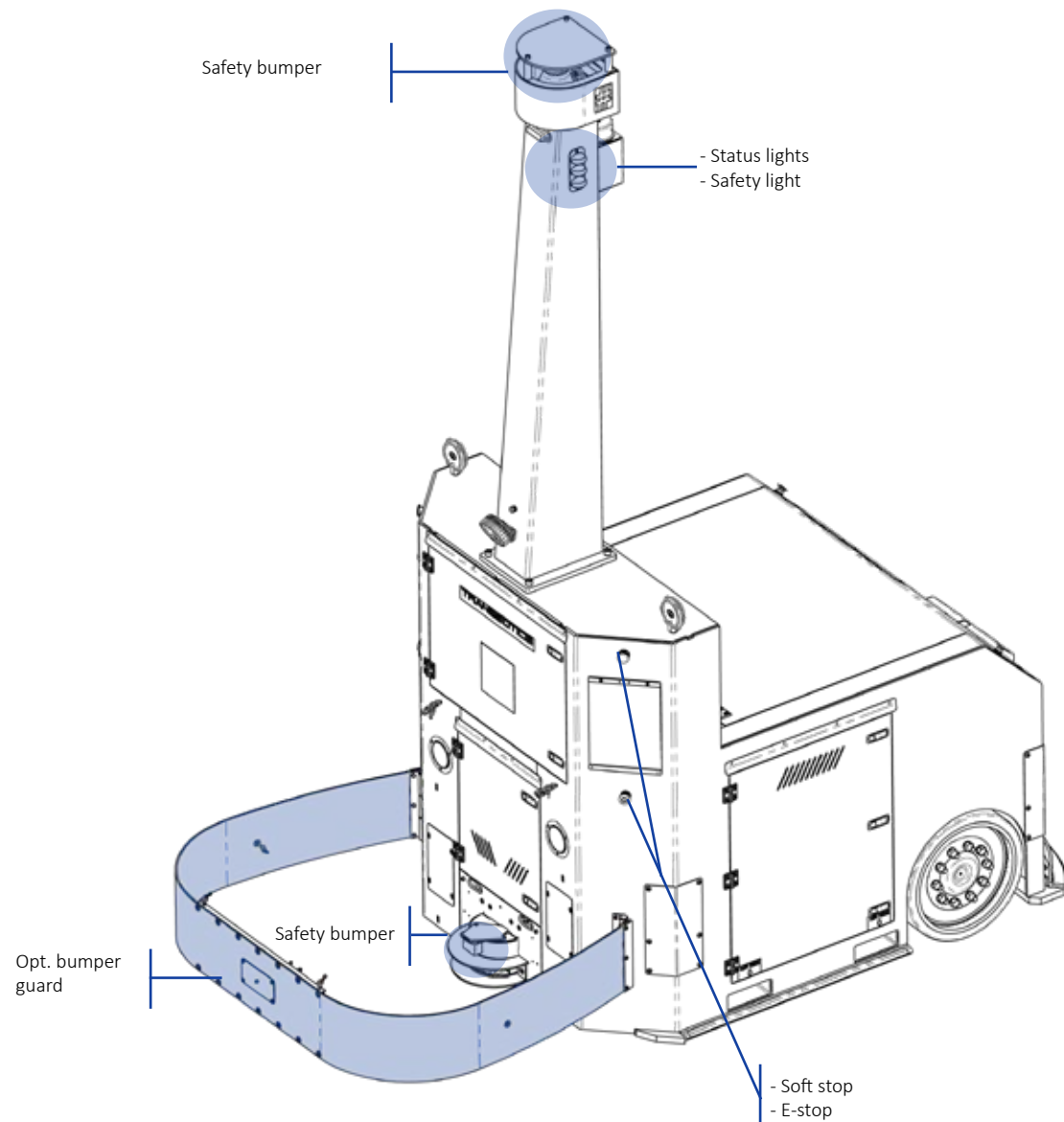

## AVAILABLE MODELS

Specification	Jackpin	ST25	ST50	ST100	ST290
Towing Capacity (Kg)	1000	2500	5000	10000	29000
Max Speed (m/sec)	0.7	1.7	1.7	1.7	1.7
Length* (mm)	2256	1295	1525	1650	2343
Width (mm)	1120	890	1065	1065	1542
Height** (mm)	1293	1575	1725	1880	1731
Wheel base (mm)	1700	780	1040	1170	1295

Tugger AGVs can be optionally equipped with automatic hitch capability allowing the vehicle to automatically couple or decouple from a trailer or cart.

\* excluding hitch

\*\*excluding laser mast





# TRANSBOTICS



704-362-1115 | 2205 BELTWAY BLVD. SUITE 100 CHARLOTTE, NC 28214  
WWW.TRANSBOTICS.COM | SALES@TRANSBOTICS.COM